

Motorkabel 1.8 m, Steckergröße 23x16 mm
Motor cable 1.8 m, Plug size 23x16 mm

ausgefahren
extended

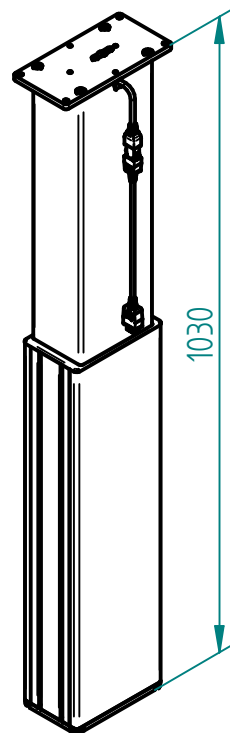

eingefahren
retracted

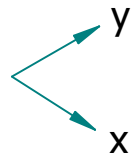
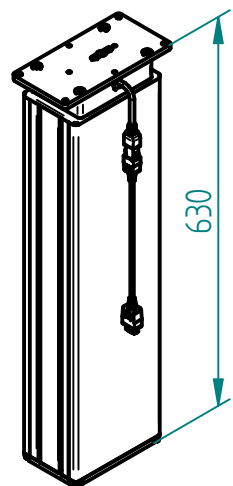

Nutengeometrie
T-Slot geometry

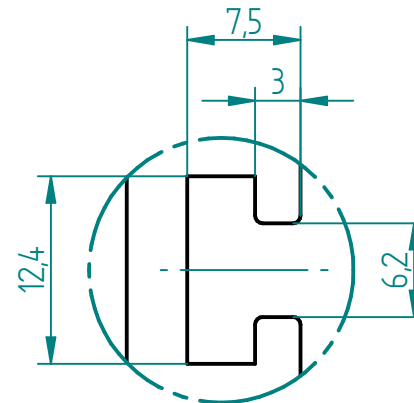

Technische Daten / technical specifications	
max. Druckbelastung / max. pressure load	3'000 N
max. Systembelastung / max. system load	abhängig von Steuerung / depending on control box
max. statische Zugbelastung / max. static tensile load	500 N
max. dynamische Zugbelastung / max dynamic tensile load	50 N
max. Hub / max. stroke	400 mm
Hubgeschwindigkeit / lifting speed	abhängig von Steuerung / depending on control box
max. stat. Biegemoment / max. static bending moment	Mbx stat. 900 Nm / Mby stat. 600 Nm
max. dyn. Biegemoment / max. dynamic bending moment	Mbx dyn. 200 Nm / Mby dyn. 300 Nm
Aluminiumprofile / aluminium profiles	farblos eloxiert / colorless anodized
Führungsart / type of guidance	Gleitführung (Kunststoff) / slide (plastics)

01	05.04.2024	thsp	dyn. Biegemomente angepasst
Index	Datum / Date	Name	Änderungsmittlung / notification of change
Allgemeintoleranzen / general tolerance ISO 2768-mK			MATERIAL
			GEWICHT / WEIGHT 11.700 kg
GEZEICHNET / DRAWN	21.03.2024	thsp	BEZEICHNUNG / PART NAME Hubsäule SN 1340
GEPRÜFT / CHECKED	21.03.2024	tiho	Lifting column SN 1340
ERGO SWISS table lift systems		ZEICHNUNGSNUMMER / DRAWING NUMBER a-911.00104	ARTIKELNUMMER / PART NUMBER 911.00104
		INDEX 01	FORMAT A3