

Motorkabel 2 m, Steckergröße 23x16 mm
Motor cable 2 m, Plug size 23x16 mm

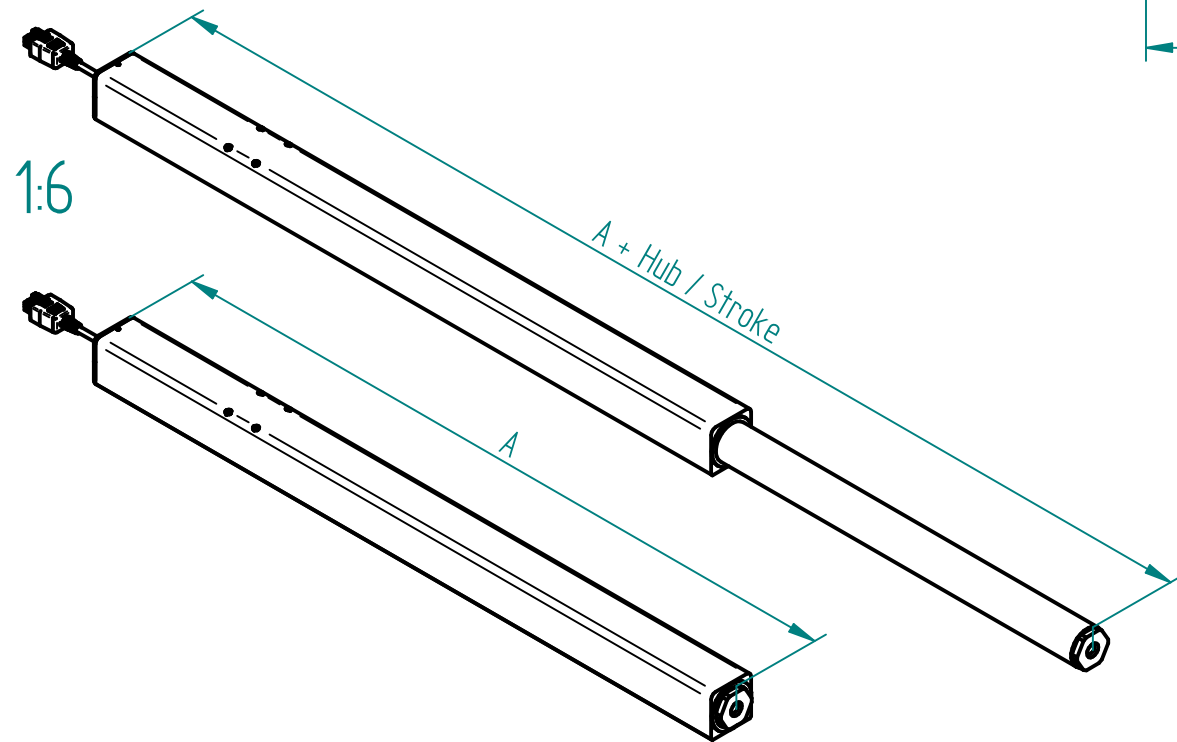
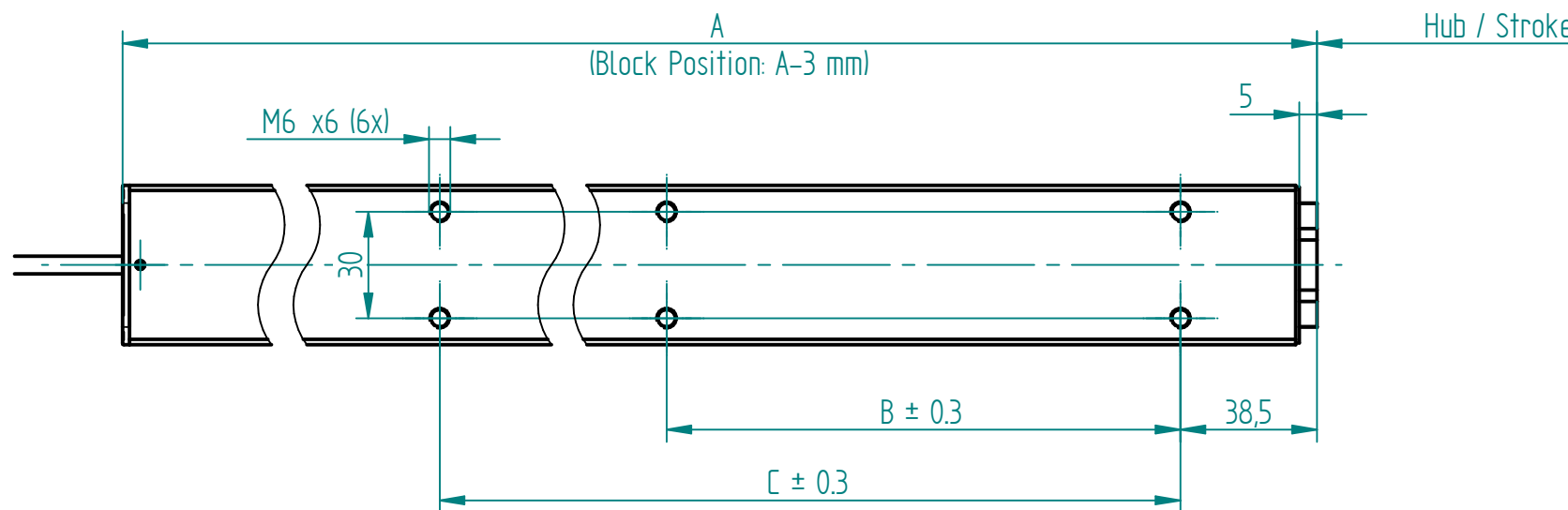
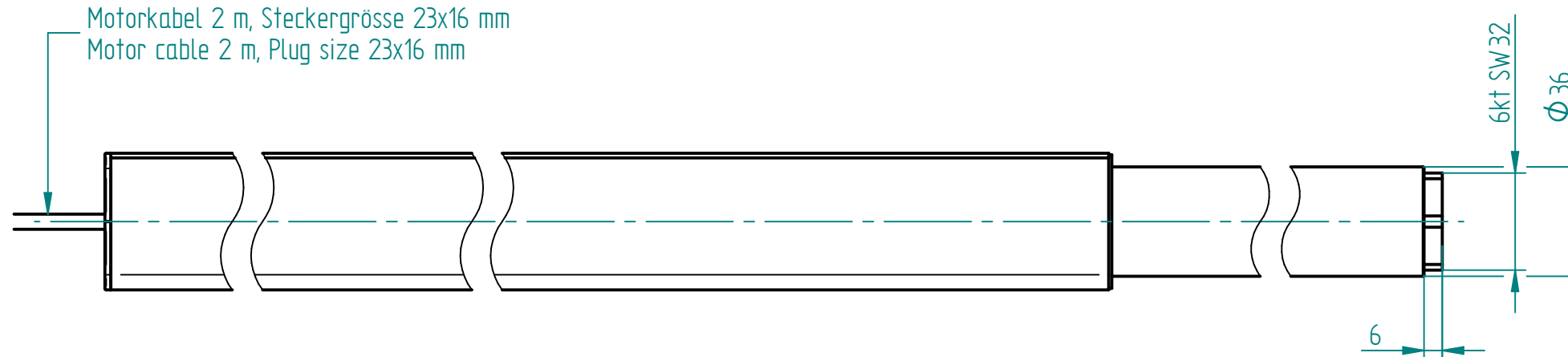

Artikelnr. / Article-No.	Name	Hub / Stroke	A	B	C
904.02003	SLG.3 1330	300	599	145	340
904.02004	SLG.3 1340	400	699	145	340

Technische Daten / technical specifications	
max. Druckbelastung / max. pressure load	1'500 N
max. Systembelastung / max. system load	abhängig von Steuerung / depending on control box
max. Zugbelastung / max. tensile load	1'500 N
Hubgeschwindigkeit / lifting speed	abhängig von Steuerung / depending on control box
max. stat. Biegemoment / max. static bending moment	Mb stat. 200 Nm
max. dyn. Biegemoment / max. dynamic bending moment	Mb dyn. 80 Nm
Aussenprofil / outer profile	Aluminium / aluminum
Innenprofil / inner profile	Stahl / steel
Führungart / type of guidance	Gleitführung (Messing) / slide (brass)

Index	Datum / Date	Name	Änderungsmittelung / notification of change
GEZEICHNET / DRAWN	02.02.2022	bema	GEWICHT / WEIGHT -----
GEPRÜFT / CHECKED	02.02.2022	tiho	BEZEICHNUNG / ASSEMBLY NAME Linear unit SLG.3 13xx
ERGO SWISS table lift systems		MAßSTAB / SCALE 1:2	ARTIKELNUMMER / ASSEMBLY NUMBER 904.02XXX
u-904.021		INDEX 00	FORMAT A3