

8x ϕ 5.3 (inkl. 4x Schraube M6x20 gewindefurchend)
 8x ϕ 5.3 (incl. 4x Screw M6x20 self-tapping)

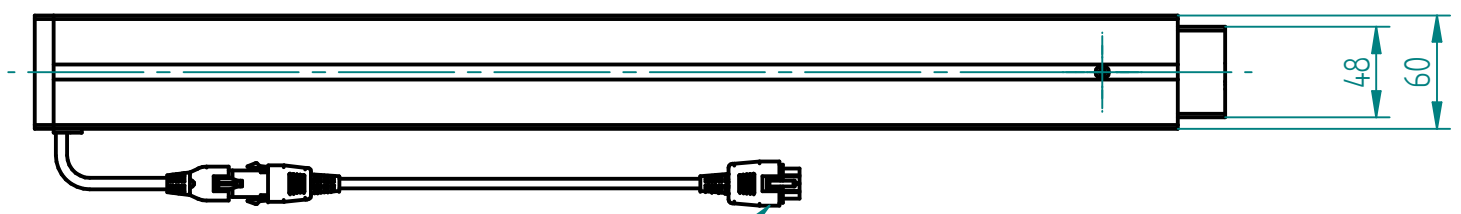

Motorkabel 1.8 m, Steckergröße 23x16 mm
 Motor cable 1.8 m, Plug size 23x16 mm

ausgefahren
 extended

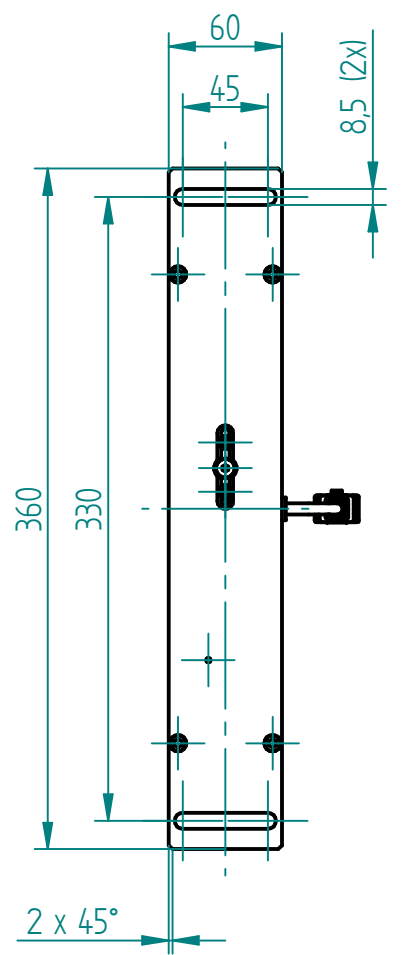
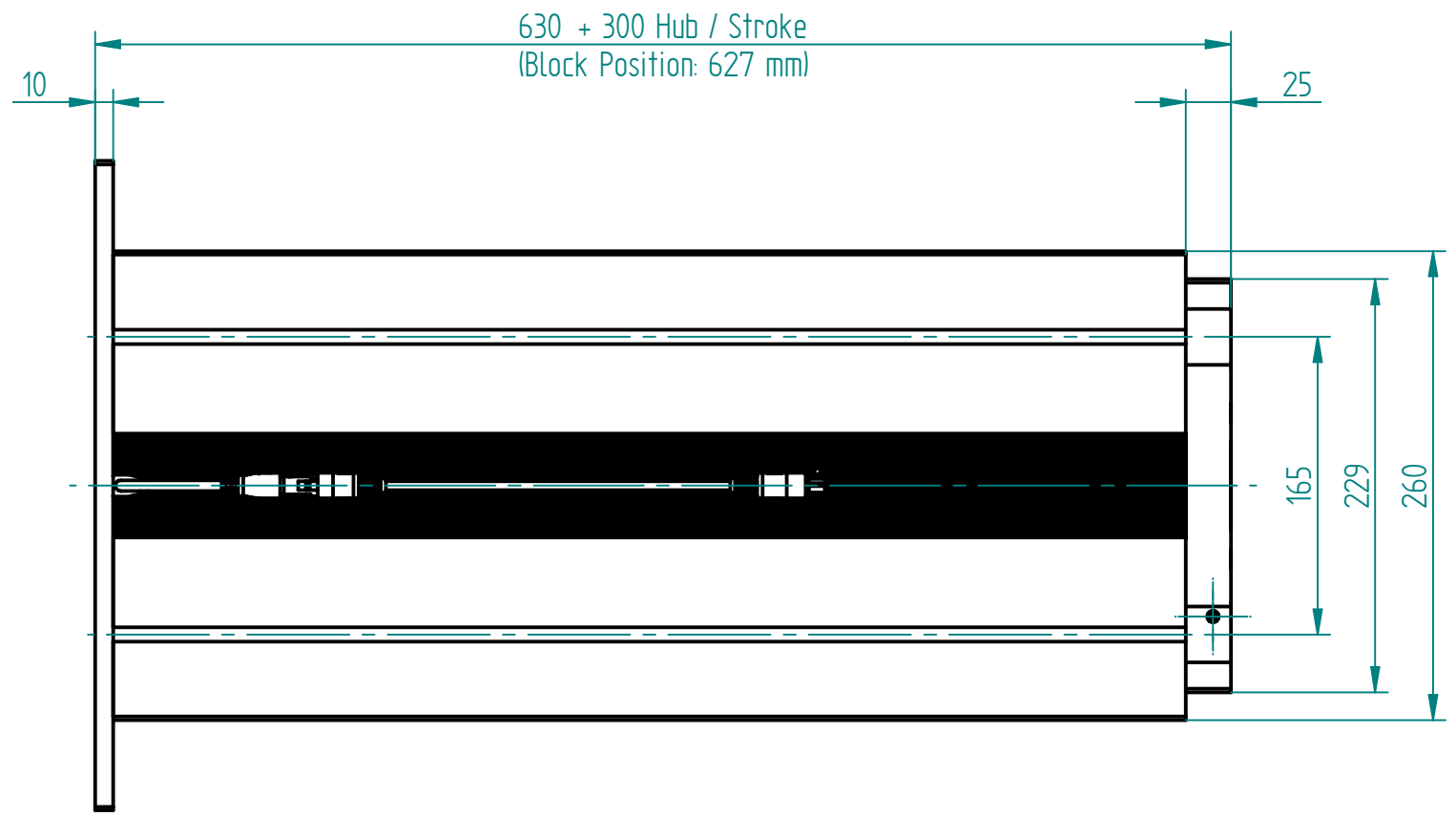
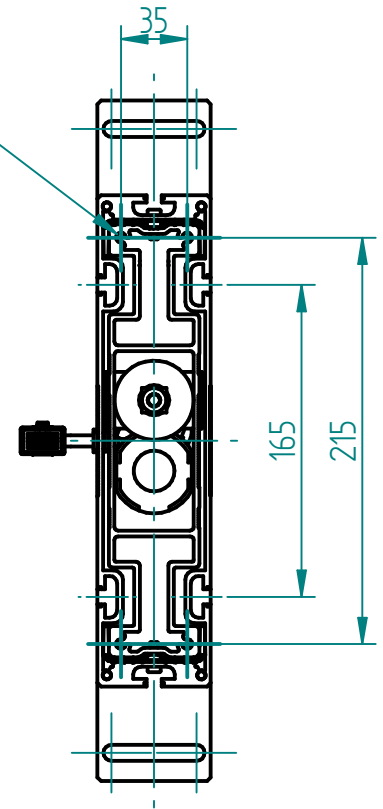
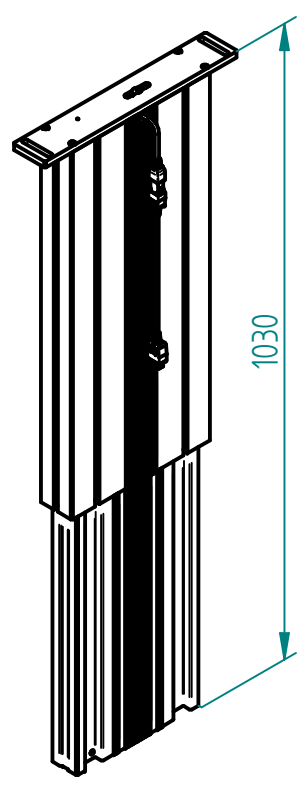

eingefahren
 retracted

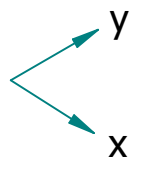
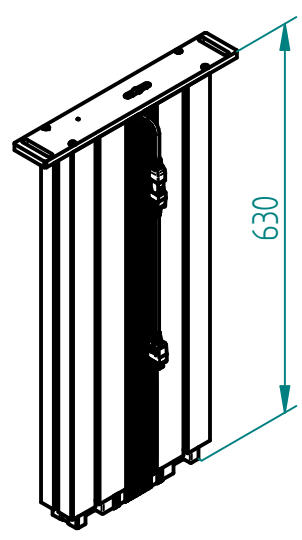

Nutengeometrie
 T-Slot geometry

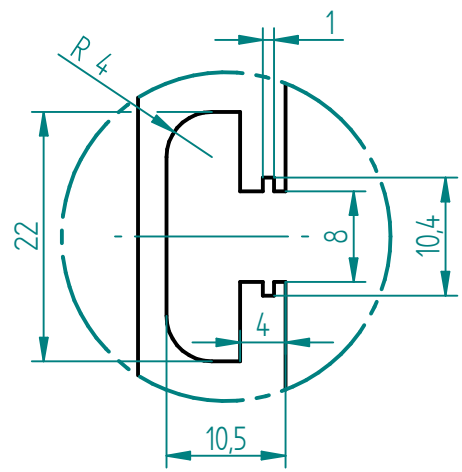

Technische Daten / technical specifications

max. Druckbelastung / max. pressure load	2'000 N
max. Systembelastung / max. system load	abhängig von Steuerung / depending on control box
max. statische Zugbelastung / max. static tensile load	500 N
max. dynamische Zugbelastung / max dynamic tensile load	50 N
max. Hub / max. stroke	400 mm
Hubgeschwindigkeit / lifting speed	abhängig von Steuerung / depending on control box
max. stat. Biegemoment / max. static bending moment	Mbx stat. 1'200 Nm / Mby stat. 450 Nm
max. dyn. Biegemoment / max. dynamic bending moment	Mbx dyn. 550 Nm / Mby dyn. 200 Nm
Aluminiumprofile / aluminium profiles	farblos eloxiert / colorless anodized
Führungsart / type of guidance	Gleitführung (Kunststoff) / slide (plastics)

Index	Datum / Date	Name	Änderungsmittelung / notification of change	
	DATUM / DATE	NAME	GEWICHT / WEIGHT	BEZEICHNUNG / ASSEMBLY NAME
GEZEICHNET / DRAWN	22.07.2021	bema	11.539 kg	Hubsäule SK 1440
GEPRÜFT / CHECKED	22.07.2021	tiho	MABSTAB / SCALE 1:5	Lifting column SK 1440
ERGO SWISS table lift systems		ZEICHNUNGSNUMMER / DRAWING NUMBER a-910.00004	ARTIKELNUMMER / ASSEMBLY NUMBER 910.00004	INDEX 00
			FORMAT A3	