

Technische Daten / technical specifications	
max. Traglast pro Hubsäule / max. load per lifting column	1'500 N
max. Systembelastung / max. system load	6'000 N
max. statische Zugbelastung / max. static tensile load	1'500 N
max. Hub / max. stroke	300 mm
Hubgeschwindigkeit / lifting speed	9 mm/s
Aluminiumprofile / aluminium profiles	farblos eloxiert / colorless anodized
Standrohre / standpipes	Stahl / steel
Führungsart / type of guidance	Gleitführung (Kunststoff) / slide (plastics)

- beigelegt / enclosed:**
- Steuerung SCT / Control box SCT
 - XX = länderspez. Netzkabel / XX = Country specific power cable
 - 12 = Handtaster SCT Typ Memory / 12 = Hand switch SCT Type Memory
 - Befestigungsschrauben für Tischplatte / Mounting screws for table plate

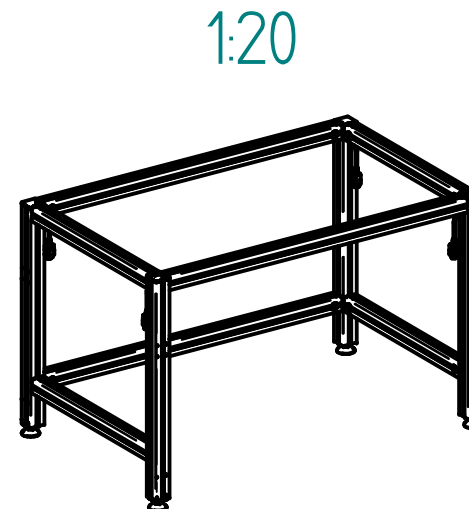
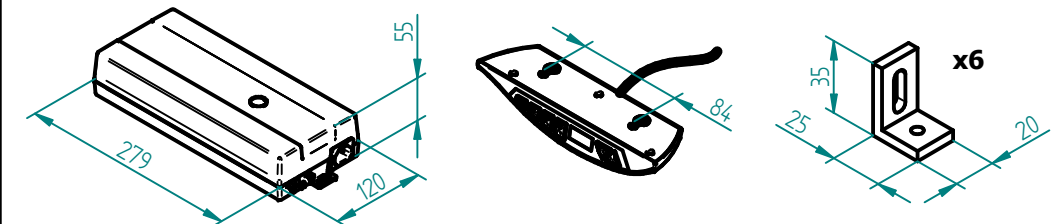

Name	A	B	C	D	XX = EU	XX = CH	XX = US
SQ.3 4330 595 XX 12	550	595	640	700 - 900	907.52071	907.52171	907.52271
SQ.3 4330 795 XX 12	750	795	840	900 - 1100	907.52072	907.52172	907.52272
SQ.3 4330 995 XX 12	950	995	1040	1100 - 1400	907.52073	907.52173	907.52273
SQ.3 4330 1195 XX 12	1150	1195	1240	1300 - 1700	907.52074	907.52174	907.52274
SQ.3 4330 1595 XX 12	1550	1595	1640	1700 - 2100	907.52075	907.52175	907.52275

Index	Datum / Date	Name	Änderungsmittteilung / notification of change	
	DATUM / DATE	NAME	GEWICHT / WEIGHT	BEZEICHNUNG / ASSEMBLY NAME
GEZEICHNET / DRAWN	04.02.2022	tiho	----	Untergestell SQ.3 4330 XXXX XX 12
GEPRÜFT / CHECKED	04.02.2022	anhe	MABSTAB / SCALE 1:10	Frame SQ.3 4330 XXXX XX 12
ERGO SWISS Dynamic Systems		ZEICHNUNGSNUMMER / DRAWING NUMBER	ARTIKELNUMMER / ASSEMBLY NUMBER	INDEX
		u-907.123	907.52XXX	00
				FORMAT
				A3