

| Technische Daten / technical specifications                |  |
|--|--|
| max. Traglast pro Hubstütze / max. load per lifting column | 1'500 N                                      |
| max. Systembelastung / max. system load                    | 6'000 N                                      |
| max. statische Zugbelastung / max. static tensile load     | 1'500 N                                      |
| max. Hub / max. stroke                                     | 400 mm                                       |
| Hubgeschwindigkeit / lifting speed                         | 9 mm/s                                       |
| Aluminiumprofile / aluminium profiles                      | farblos eloxiert / colorless anodized        |
| Standrohre / standpipes                                    | Stahl / steel                                |
| Führungsart / type of guidance                             | Gleitführung (Kunststoff) / slide (plastics) |

- beigelegt / enclosed:**
- Steuerung SCT / Control box SCT
  - XX = länderspez. Netzkabel / XX = Country specific power cable
  - 12 = Handtaster SCT Typ Memory / 12 = Hand switch SCT Type Memory
  - Befestigungsschrauben für Tischplatte / Mounting screws for table plate

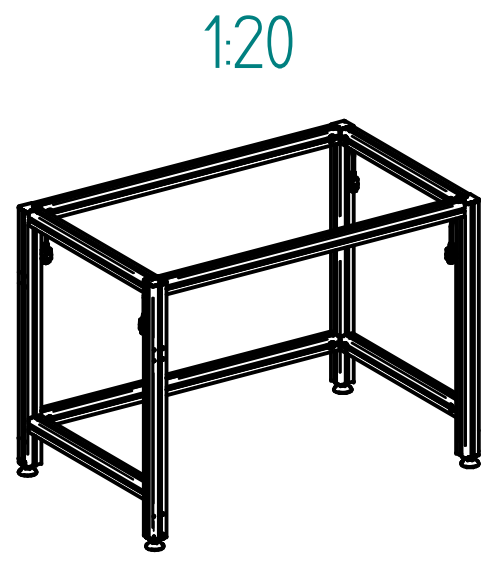
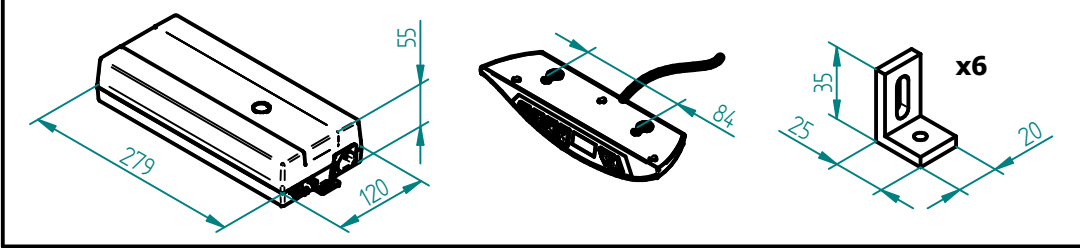

| Name                 | A    | B    | C    | D           | XX = EU   | XX = CH   | XX = US   |
|----------------------|------|------|------|-------------|-----------|-----------|-----------|
| SQ.3 4340 595 XX 12  | 550  | 595  | 640  | 700 - 900   | 907.52081 | 907.52181 | 907.52281 |
| SQ.3 4340 795 XX 12  | 750  | 795  | 840  | 900 - 1100  | 907.52082 | 907.52182 | 907.52282 |
| SQ.3 4340 995 XX 12  | 950  | 995  | 1040 | 1100 - 1400 | 907.52083 | 907.52183 | 907.52283 |
| SQ.3 4340 1195 XX 12 | 1150 | 1195 | 1240 | 1300 - 1700 | 907.52084 | 907.52184 | 907.52284 |
| SQ.3 4340 1595 XX 12 | 1550 | 1595 | 1640 | 1700 - 2100 | 907.52085 | 907.52185 | 907.52285 |

| Index                      | Datum / Date | Name                              | Änderungsmittlung / notification of change                            |
|----------------------------|--------------|-----------------------------------|---|
| GEZEICHNET / DRAWN         | 03.02.2022   | tiho                              | separ. Stückliste mit gleicher Nr. / sep. list of parts with same no. |
| GEPRÜFT / CHECKED          | 03.02.2022   | anhe                              | MABSTAB / SCALE 1:10  |
| ERGO SWISS Dynamic Systems |              | ZEICHNUNGSNUMMER / DRAWING NUMBER | ARTIKELNUMMER / ASSEMBLY NUMBER                                       |
|                            |              | u-907.124                         | 907.52XXX   |
|                            |              |                                   | INDEX 00  |
|                            |              |                                   | FORMAT A3   |