

1 System configuration

Use following table to configurate your personal system:

1. # of lifting columns: How many lifting columns do you need for your application?
(1 – 4)
2. Stroke length: How much stroke length do you need?
(max. 300 or max. 400 mm) (*max. 12" or max. 16"*)
3. Max. system load: How much weight do you need to lift?
(max. 300 kg) (*max. 660 lbs*)



NOTE

- Weight of table plate/frame must be included into calculation
- Avoid uneven load distribution
- No high impact loads allowed
- Consider max. allowed side forces and bending moments

4. Lifting column type: The table shows the correct type of lifting column, fitting your configuration.
 - For more information please check the data sheets and drawings
5. Control box type: The table shows the correct type of control box, fitting your configuration.
 - For more information please check the instruction manual
6. Lifting speed: The table shows the lifting speed of the system. All lifting columns drive synchronously.
7. Duty cycle On/Off: When operating the system with max. load, strong heat is generated during the lifting movement inside the gearbox, the spindle nut and the control box. For the components to be able to cool down, it is important to take enough operating breaks.

Duty cycle monitoring:

After a specific operating time «On», the control box will automatically pause «Off» for a while, before allowing the user to continue with operating.

2 Spindle Lifting System SL / SK / SM 14xx

# Lifting elements	Max. System load [kg] (lbs)	Stroke length [mm] (in)	Lifting element Typ	Control type 24 V	# of cycles per load-percentage at full Battery charge ②			Lifting speed	Duty Cycle [On/Off]
					100%	50%	0%		
1	150 (330)	300 (12")	① 1430	SCT (V1991)	45	90	140	6 - 7.5 mm/s (0.24 - 0.3 "/s) Load dependent	1/9 min
		400 (16")	① 1440	SCT (V1990)	35	70	110		
2	300 (660)	300 (12")	① 1430	SCT (V1991)	30	50	80		
		400 (16")	① 1440	SCT (V1990)	25	40	60		

① Lifting column SL, SK, SM, SN or SO

② The maximum number of cycles depends on the status of the battery-lifespan

Lifting column type	Max. pressure load	Max. tensile load
① 14xx	1'500 N (336 lbf)	stat. 500 N (112 lbf) dyn. 50 N (11 lbf)

① Lifting column SL, SK, SM, SN or SO

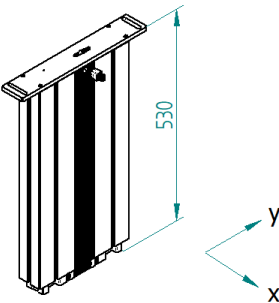
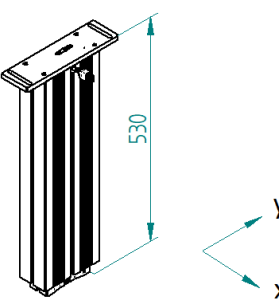
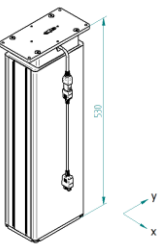
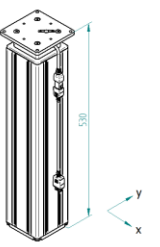
Lifting column SL / SK ①	Lifting column SM ①
 <p>Mbx stat. 1'200 Nm (885 lbf·ft) Mby stat. 450 Nm (332 lbf·ft) Mbx dyn. 550 Nm (406 lbf·ft) Mby dyn. 200 Nm (148 lbf·ft)</p>	 <p>Mbx stat. 900 Nm (664 lbf·ft) Mby stat. 350 Nm (258 lbf·ft) Mbx dyn. 450 Nm (332 lbf·ft) Mby dyn. 150 Nm (111 lbf·ft)</p>
Lifting column SN ①	Lifting column SO ①
 <p>Mbx stat. 900 Nm (664 lbf·ft) Mby stat. 600 Nm (443 lbf·ft) Mbx dyn. 200 Nm (148 lbf·ft) Mby dyn. 300 Nm (221 lbf·ft)</p>	 <p>Mbx stat. 350 Nm (258 lbf·ft) Mby stat. 350 Nm (258 lbf·ft) Mbx dyn. 200 Nm (148 lbf·ft) Mby dyn. 200 Nm (148 lbf·ft)</p>

① Mb stat. = static bending moment = max. allowed bending moment while standstill

Mb dyn. = dynamic bending moment = max. allowed bending moment during lifting movement

3 Spindle lifting system SLA.3 / SLG.3 / SE.3/ SQ.3

# Lifting elements	Max. System load [kg] (lbs)	Stroke length [mm] (in)	Lifting element Typ	Control type 24 V	# of cycles per load-percentage at full Battery charge ②			Lifting speed	Duty Cycle [On/Off]
					100%	50%	0%		
1	125 (275)	300 (12")	① 1330	SCT (V1891)	100	200	400	6 - 8.5 mm/s (0.24 - 0.33 "/s) load dependent	1/9 min
		400 (16")	① 1340	SCT (V1890)	80	160	320		
2	250 (550)	300 (12")	① 1330	SCT (V1891)	65	130	260		
		400 (16")	① 1340	SCT (V1890)	50	100	200		
3	300 (660)	300 (12")	① 1330	SCT (V1891)	40	80	160		
		400 (16")	① 1340	SCT (V1890)	30	60	120		
4	300 (660)	300 (12")	① 1330	SCT (V1891)	30	60	120		
		400 (16")	① 1340	SCT (V1890)	25	50	100		

Lifting element type	pressure load	maximum tensile load
① 13xx	1'250 N (281 lbf)	1'250 N (281 lbf)

- ① Linear unit SLA.3, linear unit SLG.3, lifting column SE.3, lifting column SQ.3
 ② The maximum number of cycles depends on the status of the battery-lifespan

Linear unit type	Max. allowed bending moments ①
Linear unit SLA.3	Mb stat. 150 Nm (111 lbf·ft) Mb dyn. 50 Nm (37 lbf·ft)
Linear unit SLG.3	Mb stat. 200 Nm (148 lbf·ft) Mb dyn. 80 Nm (59 lbf·ft)
Lifting column SE.3	Mb stat. 300 Nm (221 lbf·ft) Mb dyn. 120 Nm (89 lbf·ft)
Lifting column SQ.3	Mb stat. 200 Nm (148 lbf·ft) Mb dyn. 80 Nm (59 lbf·ft)

- ① Mb stat. = static bending moment = max. allowed bending moment while standstill
 Mb dyn. = dynamic bending moment = max. allowed bending moment during lifting movement

4 Spindle lifting system SNT1770

# Lifting elements	Max. System load [kg] (lbs)	Stroke length [mm] (in)	Lifting element Typ	Control type 24 V	# of cycles per load-percentage at full Battery charge ②			Lifting speed	Duty Cycle [On/Off]
					100%	50%	0%		
1	150	700	SNT 1770	SCT (V6090)	91	143	197	25	1/9 min
2	300	700	SNT 1770	SCT (V6090)	43	58	84		
3	300	700	SNT 1770	SCT (V6090)	31	42	59		
4	300	700	SNT 1770	SCT (V6090)	31		48		





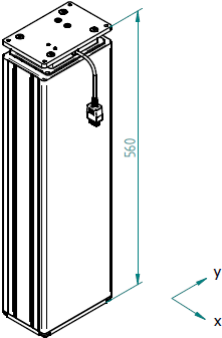



Lifting element type	pressure load	maximum tensile load
1770	1'500 N (336 lbf)	stat. 500 N dyn. 50 N

① The maximum number of cycles depends on the status of the battery-lifespan

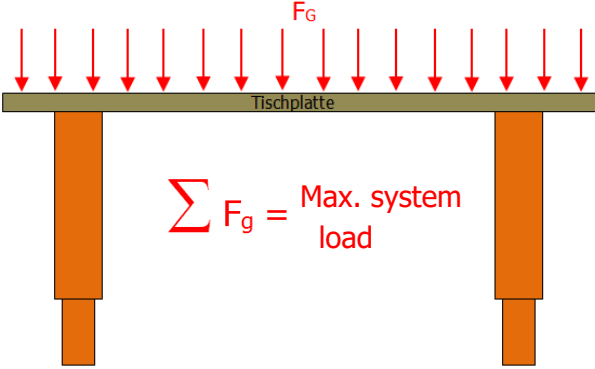
Lifting column SNT	
	<p>Mbx stat. 1'000 Nm ① Mby stat. 750 Nm ①</p> <p>Mbx dyn. 600 Nm ① Mby dyn. 300 Nm ①</p>



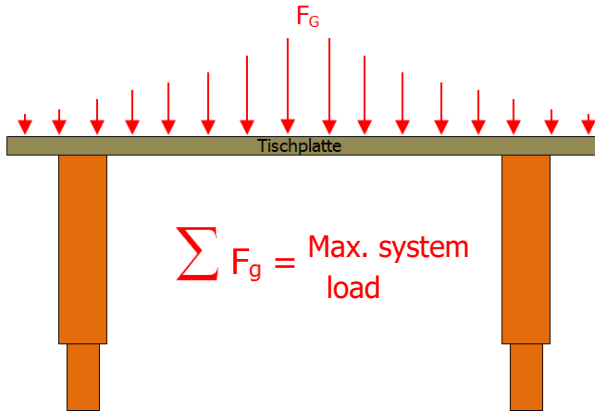

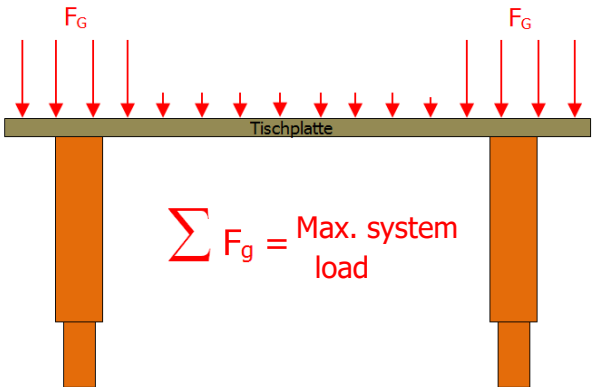
① Mb stat. = static bending moment = max. allowed bending moment while standstill
Mb dyn. = dynamic bending moment = max. allowed bending moment during lifting movement

5 Table frame – allowed loads

Evenly distributed load	
<p>NOTE</p> <p> One lifting column SX 14xx can lift max. 1'500 N (330 lbs)! One lifting column SLX 13xx can lift max. 1'250 N (275 lbs)!</p> <p>ATTENTION</p> <p> High impact loads on an already heavily loaded system are not allowed!*</p>	
Centrally distributed load	
<p>NOTE</p> <p> One lifting column SX 14xx can lift max. 1'500 N (330 lbs)! One lifting column SLX 13xx can lift max. 1'250 N (275 lbs)!</p> <p>NOTE</p> <p> Consider max. allowed side forces and bending moments!</p> <p>ATTENTION</p> <p> Stosskräfte sind bei maximaler Zuladung nicht erlaubt! *</p>	
Load on lifting columns	
<p>NOTE</p> <p> One lifting column SX 14xx can lift max. 1'500 N (330 lbs)! One lifting column SLX 13xx can lift max. 1'250 N (275 lbs)!</p> <p>ATTENTION</p> <p> High impact loads on an already heavily loaded system are not allowed!*</p>	

* It is not allowed to place the max. load onto the table in a fast motion (crane or lift truck)!

6 General information

<p>Control box SCT4 iSMPS 24V</p>	<p>Cable remote control SCT Memory T6</p>	
 <p>124.4xx9x</p>	 <p>124.00281</p>	
<p>Exchangeable battery 10A</p>	<p>Holder for Exchangeable battery 10A</p>	<p>Charging station for Exchangeable battery 10A</p>
 <p>124.00271</p>	 <p>124.00272</p>	 <p>124.00274 Charging time: 5 h</p>

Battery:

The battery beeps when the charge is 25% or less. After that, it should not be discharged further. Otherwise this will have an impact on the operating life. The battery should be charged to 70-80% every 3 months.

Overload:

Low overload: overcurrent fault E60; Load can be removed and continued.
Higher overload: Everything turns black. After a short charge in the mains; the battery works again.

Other voltage source:

The control 24V has a sticker that it has to be operated only with our exchangeable battery.



It is possible to use another voltage source such as the battery from Ergoswiss AG. However, the system battery with control must be recertified and the customer must make a safety assessment of the voltage source. If a major customer wants to connect its own voltage source, Ergoswiss AG can advise the major customer with the help of Vibradorm. Ergoswiss AG assumes no liability when connecting an own voltage source.

Number of cycles of other battery:

When connecting another 24V battery, the number of cycles may vary. This number of cycles is estimated by the capacity of the battery.

The replaceable battery of Ergoswiss AG has a capacity of 6Ah.
If a battery with a capacity of 2Ah is used, the battery can only drive 1/3 of the number of cycles.
If a battery with a capacity of 20 Ah is used, the battery can run more than three times the number of cycles.