

Schlauch 4m vormontiert
Tubing 4m pre-mounted

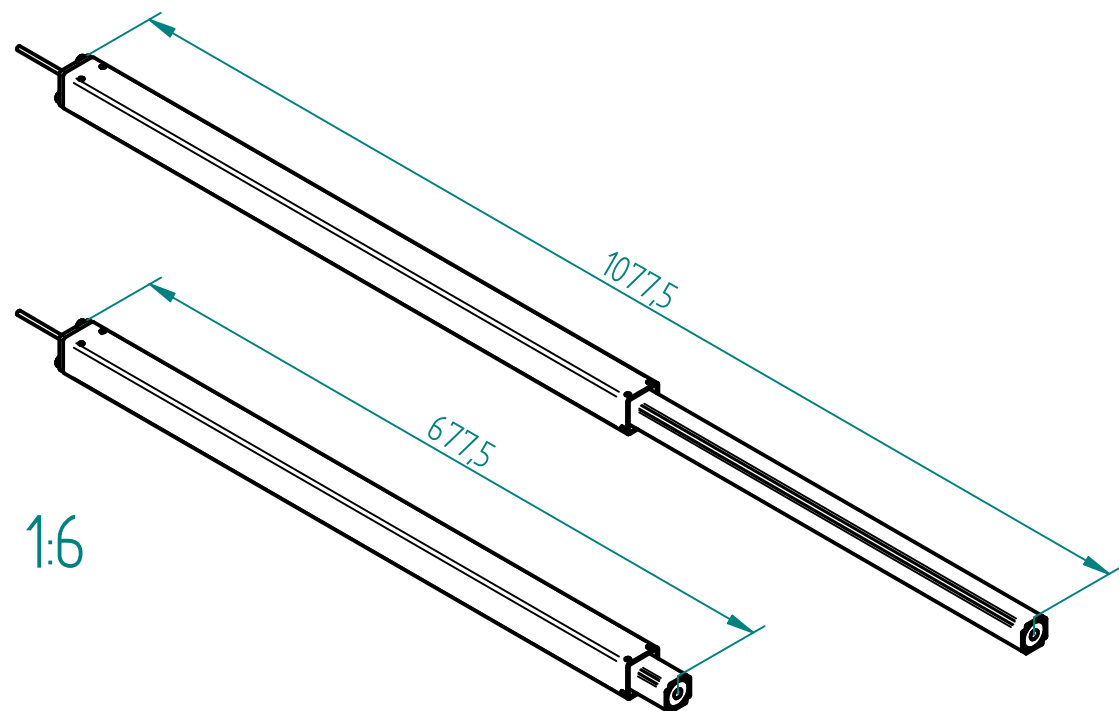
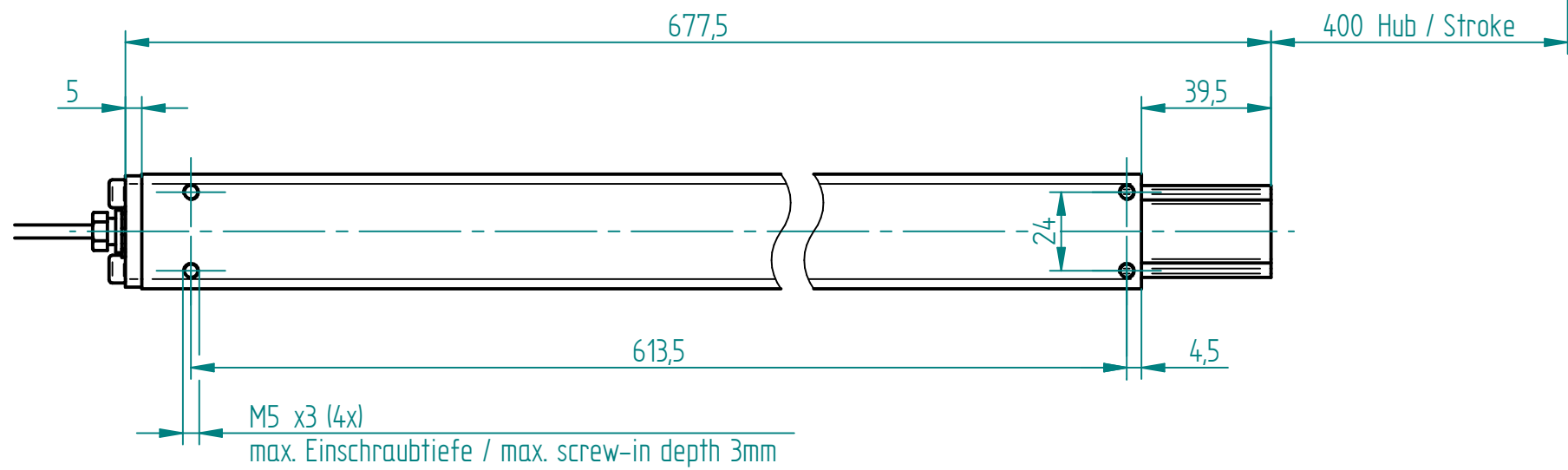
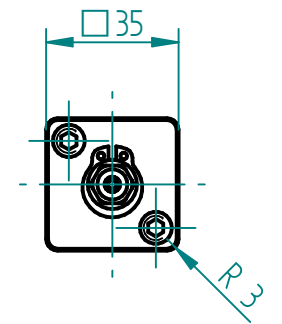
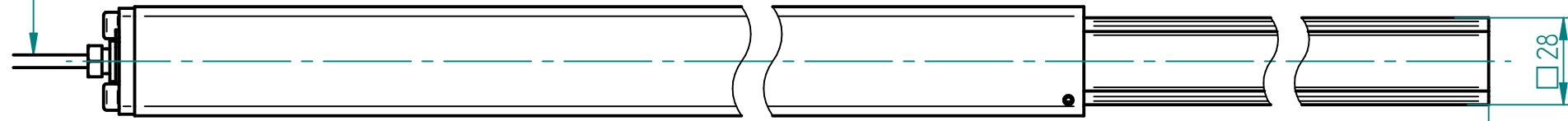

1:6

Technische Daten / technical specifications	
max. Traglast / max. load	1500 N
max. Systembelastung / max. system load	abhängig von Pumpe / depending on pump
max. Hub / max. stroke	400 mm
max. stat. Biegemoment / max. static bending moment	Mb stat. 200 Nm
max. dyn. Biegemoment / max. dynamic bending moment	Mb dyn. 80 Nm
Aussenprofil / outer profile	Stahl (RAL 9006) / steel (RAL 9006)
Innenprofil / inner profile	Stahl verzinkt / steel galvanized
Führungsart / type of guidance	Kugelführung (Stahl) / ball guide (steel)

02	23.10.2014	sc	0783: Neu mit Doppeldichtung
01	17.06.2014	sc	0760: Neu Einschweissplatte bündig und rund
Index	Datum / Date	Name	Änderungsmittlung / notification of change
GEZEICHNET / DRAWN	28.10.2013	sc	sep. Stückliste mit gleicher Nr. / sep. list of parts with same no.
GEPRÜFT / CHECKED	28.10.2013	mk	MABSTAB / SCALE 1:2
		ZEICHNUNGSNUMMER / DRAWING NUMBER	ARTIKELNUMMER / ASSEMBLY NUMBER
		a-306.10024	306.10024
		INDEX	FORMAT
		02	A3