

4x  $\phi$  5.3 (inkl. Schraube M6x20 gewinderfurchend)  
 4x  $\phi$  5.3 (incl. screw M6x20 self-tapping)

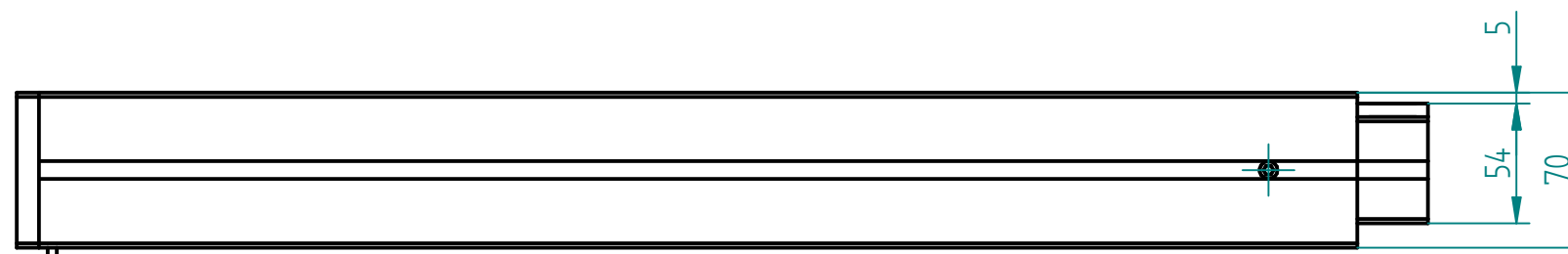

Schlauch 4m vormontiert  
 Tubing 4m pre-mounted

ausgefahren  
 extended

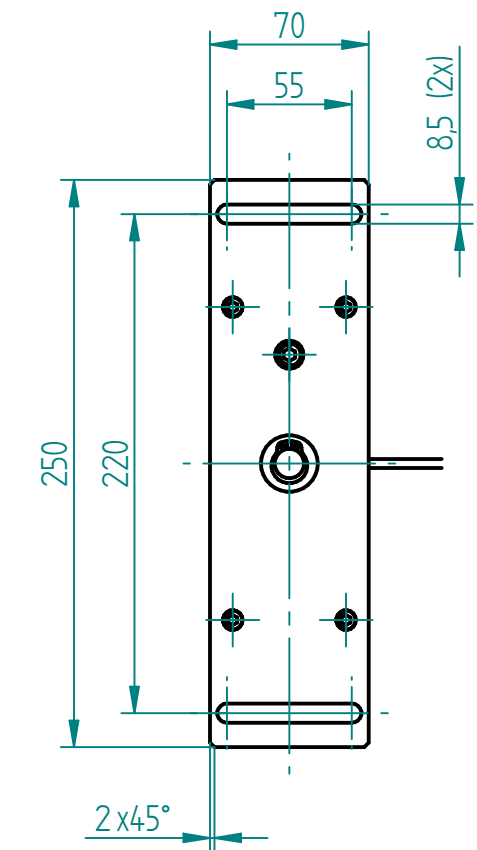
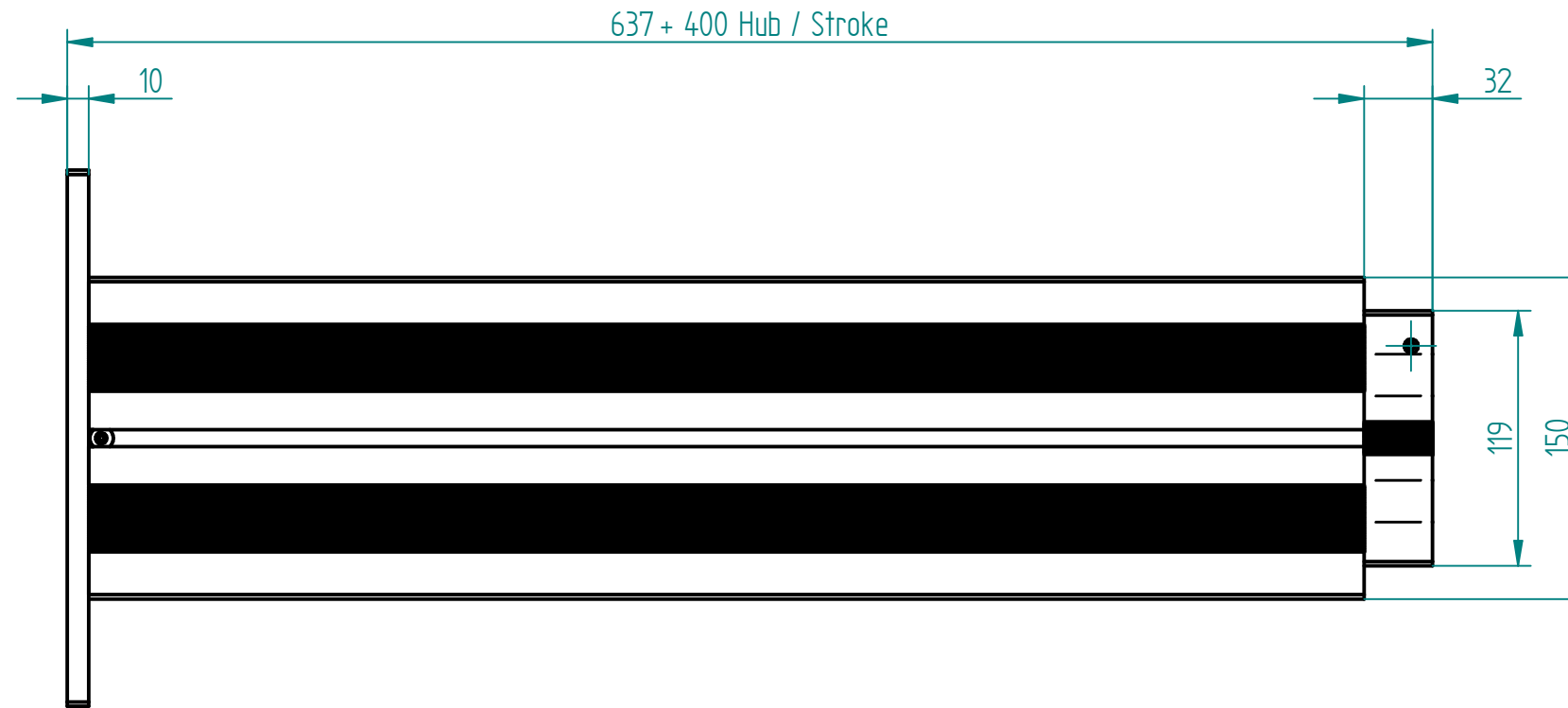
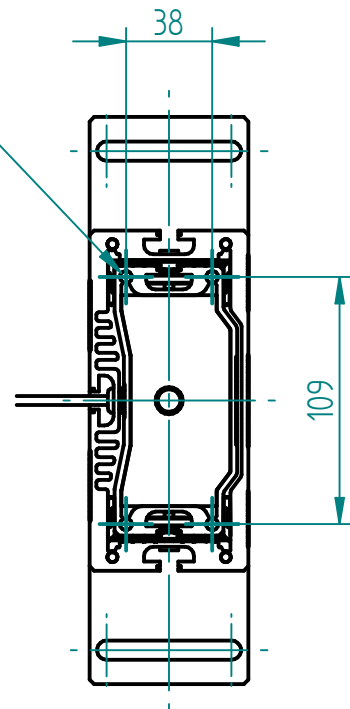
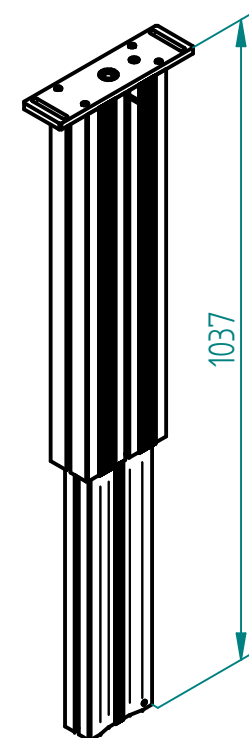

eingefahren  
 retracted

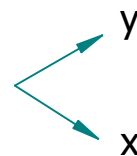

Nutengeometrie  
 T-Slot geometry

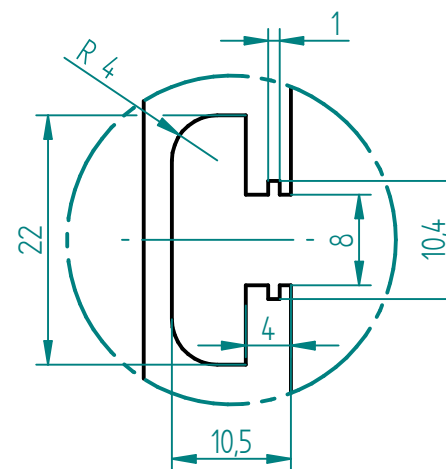

Technische Daten / technical specifications	
max. Traglast / max. load	2'500 N
max. Systembelastung / max. system load	abhängig von Pumpe / depending on pump
max. Hub / max. stroke	400 mm
max. stat. Biegemoment / max. static bending moment	Mbx stat. 900 Nm / Mby stat. 350 Nm
max. dyn. Biegemoment / max. dynamic bending moment	Mbx dyn. 450 Nm / Mby dyn. 150 Nm
Aluminiumprofile / aluminium profiles	farblos eloxiert / colorless anodized
Führungsart / type of guidance	Gleitführung (Kunststoff) / slide (plastics)

03	02.05.2017	bm	0941: Neue Adapterplatte mit Langloch
02	08.02.2017	th	0924: Kabeltülle (124.00004) ersetzt durch Kabeltülle (124.00123)
01	07.11.2016	th	0904 Adapterplatte TM: Senkbohrungen vereinheitlichen
Index	Datum / Date	Name	Änderungsmittlung / notification of change
GEZEICHNET / DRAWN	DATUM / DATE	NAME	GEWICHT / WEIGHT
02.06.2016	th	sep. Stückliste mit gleicher Nr. sep. list of parts with same no.	8.111 kg
GEPRÜFT / CHECKED	DATUM / DATE	MAßSTAB / SCALE	1:5
02.06.2016	ah		
ERGO SWISS table lift systems		ZEICHNUNGSNUMMER / DRAWING NUMBER	ARTIKELNUMMER / ASSEMBLY NUMBER
		a-306.00814	306.00814
		INDEX	FORMAT
		03	A3

Tischbein TM 1840

Table leg TM 1840