

4x ϕ 5.3 (inkl. Schraube M6x20 gewindefurchend)
 4x ϕ 5.3 (incl. Screw M6x20 self-tapping)

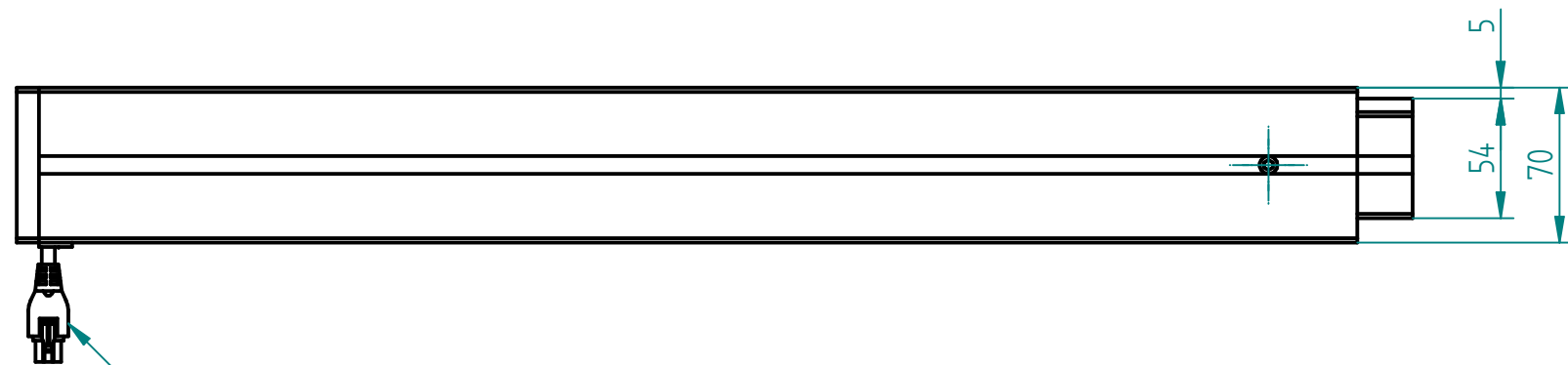

Motorkabel 1.8 m
 Motor cable 1.8 m

ausgefahren
 extended

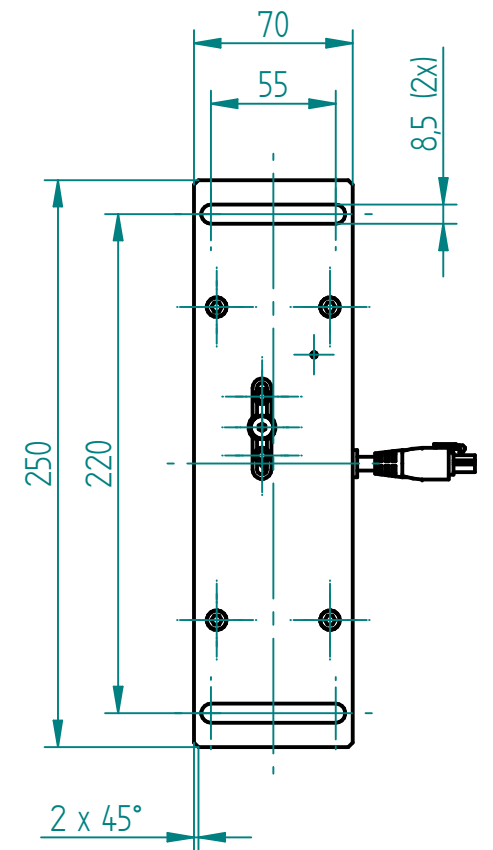
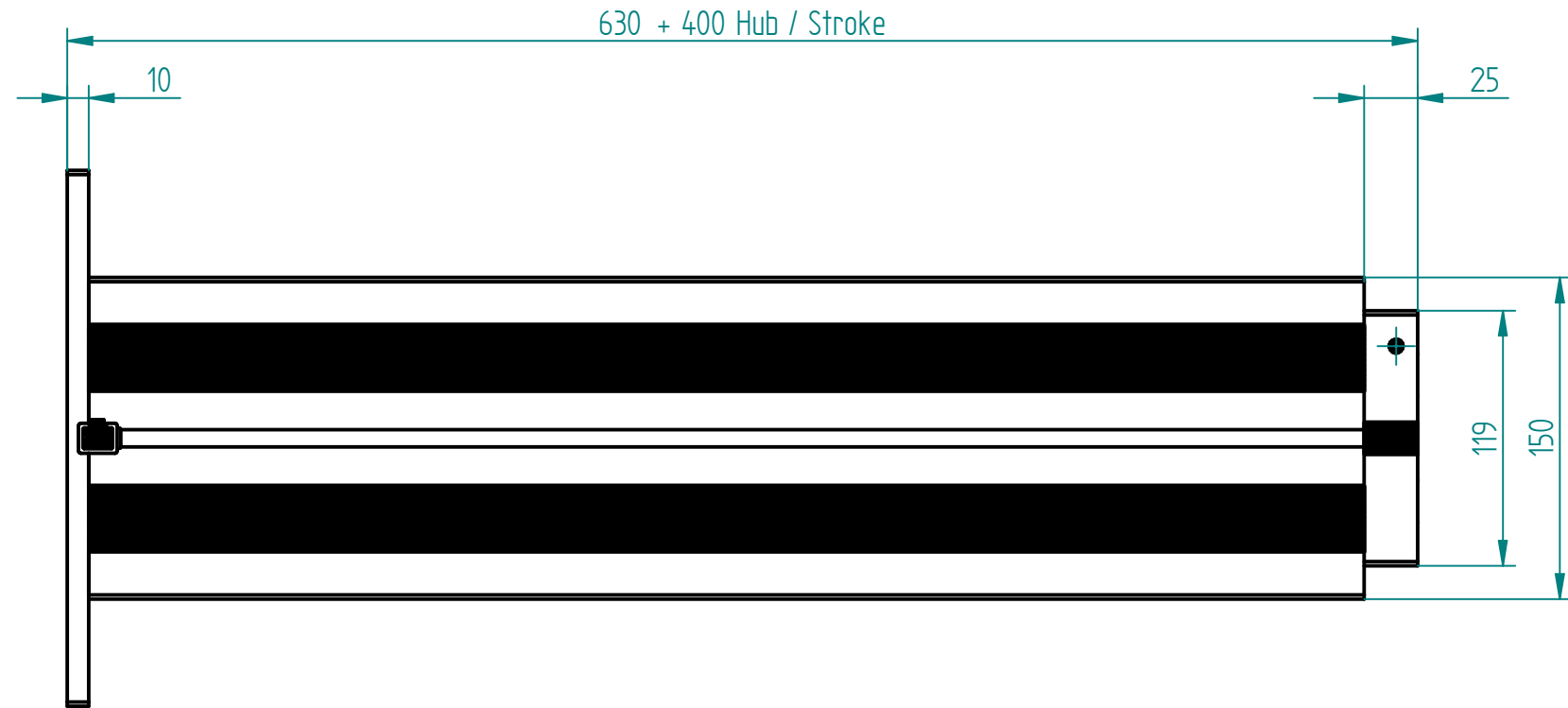
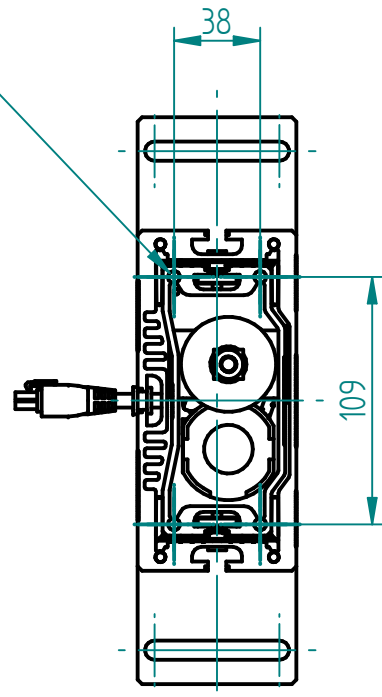
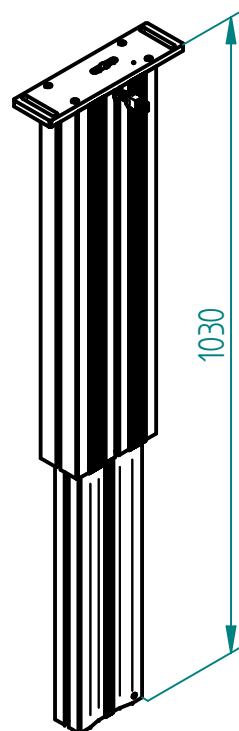

eingefahren
 retracted

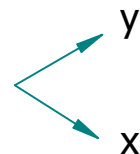

Nutengeometrie
 T-Slot geometry

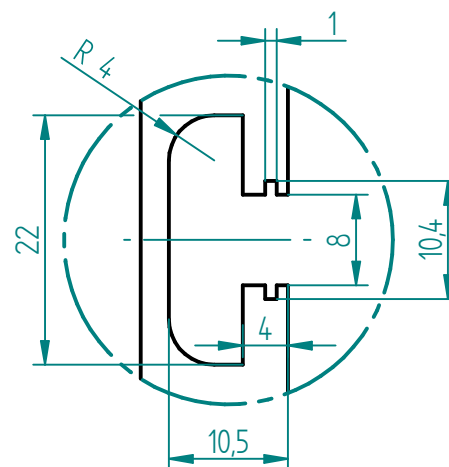

Technische Daten / technical specifications

max. Druckbelastung / max. pressure load	2'000 N
max. Systembelastung / max. system load	abhängig von Steuerung / depending on control box
max. statische Zugbelastung / max. static tensile load	500 N
max. dynamische Zugbelastung / max dynamic tensile load	50 N
max. Hub / max. stroke	400 mm
Hubgeschwindigkeit / lifting speed	12 mm/s
max. stat. Biegemoment / max. static bending moment	Mbx stat. 900 Nm / Mby stat. 350 Nm
max. dyn. Biegemoment / max. dynamic bending moment	Mbx dyn. 450 Nm / Mby dyn. 150 Nm
Aluminiumprofile / aluminium profiles	farblos eloxiert / colorless anodized
Führungsart / type of guidance	Gleitführung (Kunststoff) / slide (plastics)

05	12.12.2019	bema	1101: optisch Änderung: Langloch für Motor in Adapterplatte
04	02.05.2017	bm	0938: Neue Adapterplatte mit Langloch
03	17.05.2016	th	0894 Adapterplatte SM: 4x Gewinde M6 entfernen
02	08.01.2016	ah	0863 Adapterplatte SM: Kanten mit Radius 3mm verrunden
01	23.11.2015	sc	0839 Adapterplatte SM: beidseitig je 4x M8-Bohrungen (statt 6x Ø6.5)

Index	Datum / Date	Name	Änderungsmitteilung / notification of change	
GEZEICHNET / DRAWN	22.06.2015	sc	GEWICHT / WEIGHT	BEZEICHNUNG / ASSEMBLY NAME
GEPRÜFT / CHECKED	22.06.2015	ah	9.319 kg	Hubsäule SM 1440
		MABSTAB / SCALE	1:5	Lifting column SM 1440
ERGO SWISS table lift systems			ZEICHNUNGSNUMMER / DRAWING NUMBER	ARTIKELNUMMER / ASSEMBLY NUMBER
			a-902.00004	902.00004
			INDEX	FORMAT
			05	A3