

System Crank 4-HR 1803 D100

Part. Nr.: 501.10101

The system consists of 4 castors with hydraulic driven levelling feet.

Through the rotary motion of the hand crank the hydraulic oil is pressed out of the pump and flows through the hydraulic tubing into the connected levelling foot.

The system functions independently of load and the 4 castors operate completely synchronously. Each lifting castor is equipped with 3 m hydraulic tubing. The tubing can be cut to the required size and be easily connected to the pump.

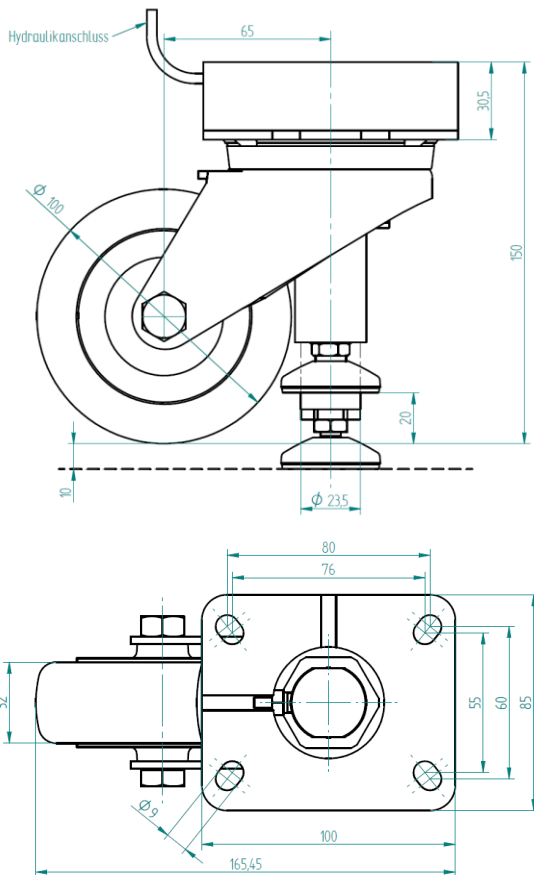

Download CAD Files on www.ergoswiss.com/en

Application

Mobile work and transport equipment can be fitted with the lifting castors and be converted into stable working surfaces. The standard system consists of 4 lifting castors. On demand, we are also able to supply systems with up to 10 lifting castors.

Castor

The castor with polyurethane wheels is made of injection-moulded, thermoplastic elastomer and has very low abrasion and low rolling friction.

Technical Data

Wheel Diameter	100mm
Wheel width	32mm
Total height	150mm
Plate size	100x85mm
Bearing Castor	Kugellager
Max. system load	750kg
Stroke	10mm
Tubing length	3m

Packaging and Accessories

The set with 4 lifting castors will be delivered in a carton package (590 x 395 x 150 mm) containing following elements:

- 5 clamping rings
- 1 connection screw (spare part)
- 1 magnet
- 1 tubing cutter
- 1 ring spanner

Assembly and operating instructionsl

